

Dental Electric Motor Instruction

Please read the Manual carefully before first use.

Thank you for purchasing MT3 Dental Electric Motor manufactured by Guilin Woodpecker Medical Instrument Co., Ltd. To ensure the correct use of device, it is recommended to carefully read the content on Installation, Operation, Maintenance, etc. in the Manual. For easier check, it is recommended to place the Manual in a position easy to access.

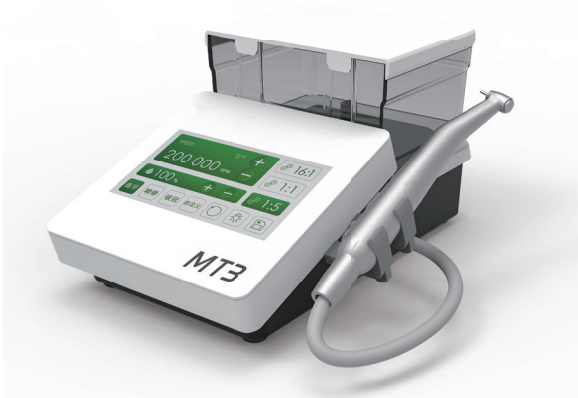

Guilin Woodpecker Medical Instrument Co., Ltd.

Content

Forward -----	1
1 Introduction -----	1
2 Basic technical parameters -----	3
3 Product performance structure and composition -----	4
4 Main unit interface -----	7
5 Function and operation -----	7
6 Safety precautions -----	9
7 Clean, disinfection, and sterilization-----	10
8 Troubleshooting-----	15
9 Storage and transport-----	15
10 After-sales service-----	16
11 Environment protection -----	16
12 Symbol instruction-----	17
13 EMC-Declaration of comformity -----	18

Forward

Guilin Woodpecker Medical Instrument Co., Ltd is a professional manufacturer researching, developing, and producing dental products. Woodpecker owns a sound quality control system and four brands, Woodpecker, DTE, DBA and RTA. Its main products include Ultrasonic Scaler, Curing light, Apex locator, Ultrasurgery, Endo Motor, Dental electric Motor, etc.

1 Introduction

Dental electric motor is for driving dental handpieces for dental surgery, Mainly used for dental aesthetics restoration, crown breaking, open marrow preparation, deburring, polishing and other aspects of power.

1.1 Precautions before operation



Dangers:

1. To prevent electric shock, do not use a wet hand to pull the power cord, and please prevent the water from entering the control circuit.
2. Keep away from explosives and flammable materials. Do not use this dental electric motor for patients who are anesthetized with nitrous oxide.
3. The device can not be used in MRI environment.



Warnings:

- (1) This dental electric motor may malfunction when used in an environment where electromagnetic interference occurs. This dental electric motor cannot be installed near the device that releases the magnetic wave. When using an ultrasonic vibrating device or an electrode knife in the vicinity, turn off the switch on the dental electric motor control panel.
- (2) MT3 requires special precautions for EMC and needs to be installed and put into use according to the EMC environment.
- (3) Device with electromagnetic transmitting will affect the normal operation of MT3. Please do not run both devices at the same time.
- (4) Do not use it in operating rooms that contain a mixture of potentially flammable gases.
- (5) To avoid possible injury or damage to the dental electric motor, make sure that the motor handpiece (hereinafter referred to as the motor) is completely stopped when changing the contra-angle. (And the contra-angle tool should be replaced by the pedal controller.)

- (6) A severe impact, such as a drop from high position, can result in damage to the dental electric motor.
- (7) Do not try to disassemble the controlling panel or motor.
- (8) After use, please immediately clean, lubricate and disinfect the dental handpiece (hereinafter referred to as the handpiece).
- (9) Do not lubricate the motor. The lubricant can cause overheating and damage the motor.
- (10) Do not use a solution with dissolving ability to clean the control panel.
- (11) Do not remove the motor cable from the motor.
- (12) After each operation, turn off the power supply.
- (13) APPLIED PART: The contra-angle.
- (14) Any serious incident that has occurred in relation to the device should be reported to manufacturer and the competent authority of the Member State in which the user and/or patient is established.
- (15) The ratio displayed on the interface of the main unit is the speed ratio of the contra-angle handpiece, please select the contra-angle handpiece with the corresponding speed ratio.

1.2 Intended use

Electrical drive including media supply for dental handpieces in the field of preventative dentistry, conservative dentistry for tasks such as the preparation of cavities and prosthodontics for tasks such as the preparation of crown.

1.3 Intended user and patient

1. Intended user: Professional dentists
2. Intended patient: Patients who need dental treatment procedure for the removal of decayed matter, cavity and crown preparations, and removal of fillings and surface finishing of tooth and restoration surfaces.

1.4 Model

MT3

1.5 Contraindications

None known

1.6 Safety requirements

Guilin Woodpecker Medical Instrument Co., Ltd. will not be liable for any direct or indirect damages and losses under the following conditions:

- The device is used to the unmentioned usages or the usages outside the scope of application.
- The operator did not use the device with the method in accordance with the procedures and requirements stipulated in the Instruction Manual.
- The wiring system of the room where the device is used does not meet the requirements of appropriate standard and other proper requirements.
- Assembling, operating, and repairing the equipment without the authorization of the Woodpecker.
- The environmental conditions in which the equipment is located or stored do not meet the requirements mentioned in the section on technical requirements.
- After each use, pull the contra-angle out from the motor in parallel, place it in the corresponding position, and powers off the main unit.
- During the process of use, the operator is in direct contact with the contra-angle. The contra-angle is made of copper.

2 Basic technical parameters

2.1 Specification of main unit

Model: MT3

Software version: MT3-V1.0.0

Size: 278.5mm×157.5mm×137mm

2.2 Specification of power

Power supply input: 100-240V~ 50/60Hz 100VA

2.3 Motor specification

Model: E-MT

Rotation speed: 2000-40 000 rpm;

Torque range: 0-5.0 Ncm

Voltage input: DC 24V

Size: $\Phi 22 \times 76.7$ mm

Tail cord length: 1.8m

Spray water source:

water pressure (2 bar ~ 5 bar), water flow > 50ml / min

Spray gas source:

air pressure (2.5 bar ~ 5 bar), air flow > 1.5L / min

2.4 Contra-angle handpiece

The E-MT Motor is compatible with the contra-angle handpiece which is

comply with the Type 2 or Type 3 of ISO 3964-2016.

2.5 Use environment

2.5.1 Ambient temperature: +5°C ~ +35°C

2.5.2 Relative humidity: 30% ~ 75%

2.5.3 Atmospheric pressure: 70kPa ~ 106kPa

2.6 Device safety classification

2.6.1 Type of protection against electric shock: Class II equipment

2.6.2 Degree of protection against electric shock: Type B applied part

2.6.3 Degree of protection against harmful ingress of water: Ordinary equipment (IPX0). Not waterproof.

2.6.4 Classified by operation mode: Intermittent operating device

2.6.5 Degree of safety application in the presence of a flammable anesthetic mixture with air, oxygen, or nitrous oxide: Equipment cannot be used in the presence of a flammable anesthetic mixture with air, oxygen, or nitrous oxide.

3 Product performance structure and composition

3.1 Safety requirements during installation

Danger: Equipment is installed on the premise that the installation must comply with appropriate standards and associated electric safety requirements.

Danger: Never install the unit in an explosive atmosphere and do not operate in areas with flammable gases (anaesthetic mixtures, oxygen, etc.).

Danger: The installation site should be protected from shocks and splashes of water or other liquids.

DANGER: Do not install the unit near or above the heat source. It must be installed in a place where the surrounding air is sufficiently circulated. There is enough space around it, especially for the exhaust fan and the back position.

WARNING: Do not place the parts directly under sunlight or ultraviolet light.

WARNING: This equipment is movable, but please handles with care.

WARNING: Make sure the connection parts are dry before connecting the wires to the unit. If necessary, blow to dry it with an air gun.

WARNING: Detachable power cords should not be installed in locations that are difficult to disconnect.

WARNING: When using manual mode, the contra-angle handpiece is less than 3 minutes per contact.

3.2 Front View of the Main Unit

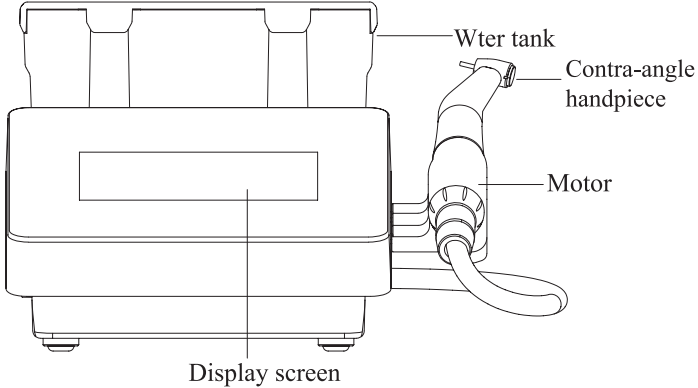

Figure 1

3.3 Rear view of the main unit

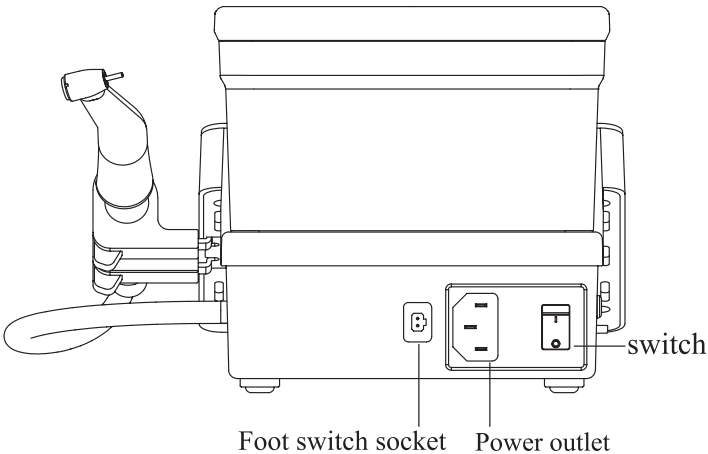

Figure 2

3.4 Connecting / disconnecting the motor and the motor cord

3.4.1 Align and insert firmly the Motor Pin into the pin holes of the Motor Cord Connector, and fasten the Motor Cord Nut securely.

3.4.2 To remove the Motor Cord from the Motor, unscrew and detach the

motor cord nut, and gently pull out the motor cord connector.

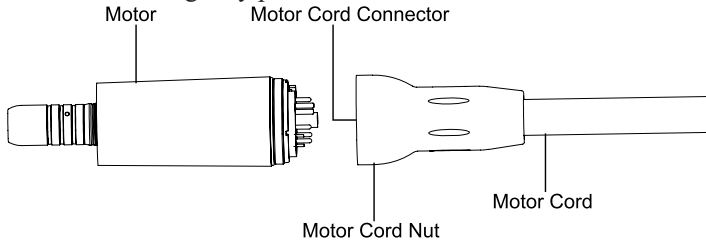

Figure 3

3.5 Schematic diagram of motor installation

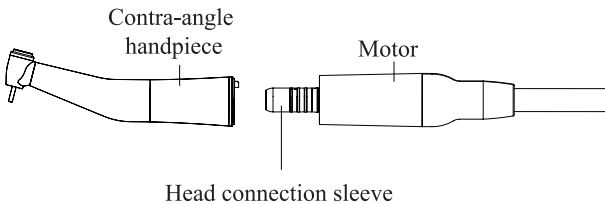

Figure 4

A. Connect, align and insert the motor and motor tail connections, twist the nut of the motor tail cord.

B. Remove the motor tail cord from the motor, unscrew and disconnect the motor wire nut, and gently exit the motor tail connector;

3.5.2 Connect/Disconnect motor and contra-angle

A. Insert the motor connecting shaft into the contra-angle, and then turn the contra-angle till you heard a “click” sound, to ensure accurate positioning;

B. When removing the contra-angle, pull the contra-angle out of the motor in parallel.

3.6 Installation steps

3.6.1 Open the package, check whether the items of the equipment are complete according to the packing list, and place the main unit on the stable surface.

3.6.2 Align the three jacks of the power cord with the three pins of the power socket on the back of the host and plug them to the end. At this time, the power cord will not be loose or shaking.

3.6.3 Foot switch installation: Align the protrusion of the foot switch cable plug with the groove of the foot connector of the host, and then

insert it to the end.

3.6.4 Water tank installation: the side with two grooves on the water tank faces the screen of the host computer, and then align the water hole plug to assemble the water tank to the bottom. At this time, the bottom of the water tank is close to the upper surface of the main unit shell.

4 Main unit interface

4.1 Main interface

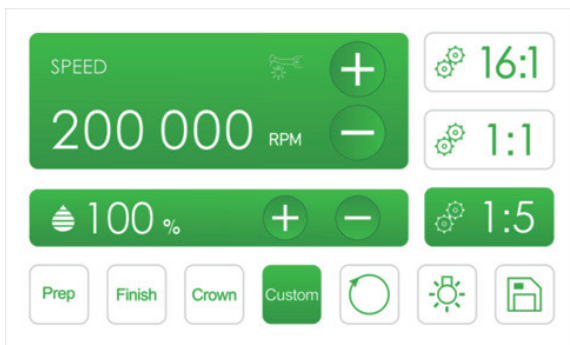

Figure 5

5 Function and operation











5.1 Install the product correctly according to the product installation steps, and the operator should face the screen.

5.2 Turn on the power switch on the main unit, the screen will display and enter the main control interface (Figure 4).

5.3 The electric motor operation is controlled by the foot switch.

5.4 Icon description

Icon	Name	Function
	Speed ratio	Select the speed of contra-angle (16:1/1:1/1:5)
	Speed/Water volume adjustment	Increase
	Speed/Water volume adjustment	Decrease

	Store	Store the set parameters
	Forward/Reverse rotation	Control the forward and reverse rotation of motor
	Light	Turn on/off the motor Light.
	Custom	User-defined mode
	Prep	Tooth preparation mode
	Finish	Refinement mode
	Crown	Crown-splitting mode
	Water volume	Display the set percentage of water
	Speed	Display the set operating speed
	Speed adjustment	Adjust the speed formerly set in the manual mode. Touch the progress bark to increase or decrease the speed.

5.5 Basic function adjustment on main unit controlling interface

5.5.1 Select speed ratio through touching key “1”. The color of the key will change when touching the key.

5.5.2 Adjust the speed/water volume of the motor by touching key “3”. Increasing or decrease speed/water volume with key “+” and “-”.

5.5.3 Switch to the forward rotation or reverse rotation by touching key “3”.

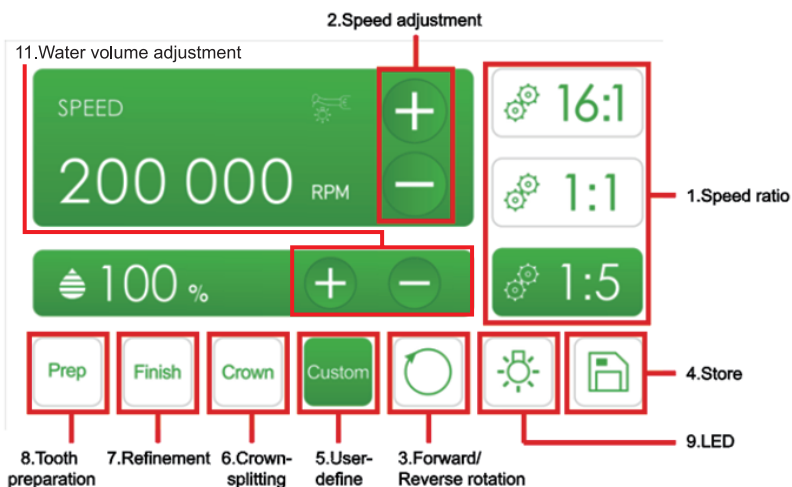

5.5.4 Store the set speed ratio, speed, mode, forward rotation/reverse rotation, and the ON/OFF of LED by touching key “4”

5.5.5 Press user-defined button “5” and enter User-define mode.

5.5.6 Press crown-splitting button “6” and enter Crown-splitting mode.

5.5.7 Press refinement button “7” and enter Refinement mode.

5.5.8 Press tooth preparation button “8” and enter Tooth preparation mode.

5.5.9 Press LED button “9” and control the ON and OFF of motor LED.

6 Safety precautions

Cautions:

6.1 For repairs and purchase of spare parts, please contact our authorized supplier.

6.2 The accuracy of the speed monitoring depends on the high-precision performance of the handpiece installed on the micro motor. If the handpiece of other manufacturers is used, the actual speed value may not be displayed correctly. To ensure the actual matching display speed, please use the matching handpiece.

6.3 Read this operating manual before use and fully understand the functions of each part.

6.4 Check the operating status of the dental electric motor before use to confirm that there is no abnormality.

- 6.5 Test the dental electric motor before use to ensure accurate operation.
- 6.6 If the dental electric motor is permanently malfunctioning (excessive vibration, noise and heat generation, etc.), please immediately close it and return it to the authorized dealer.
- 6.7 Clean the control panel with a damp cloth and turn off the power before cleaning.

7 Clean, disinfection, and sterilization

7.1 The cleaning and sterilization of motor are as follows.

Warning	 <p>Warning: 1. Before sterilization, the hose connector should be removed.</p> <ol style="list-style-type: none"> 2. Do not spray any cleaning solution or lubricant into the motor. 3. Except the motor , the other parts such as main unit, power cord and tail cord are not allowed to be sterilized. 4. Do not clean the motor in a washer-disinfectant unit. 5. The products may not be exposed to temperature above 137°C. 6. The cleaning and sterilization must be conducted before use. 7. After each treatment with medical solution, please change to a water bottle filled with pure water, adjust the water volume to the maximum, run the machine for 30secs, and clean the pipes to prevent blockage or metal rust. 8. Do not use unclean water. Never use normal saline instead of pure water.
Advice	<p>The products have been designed for a large number of sterilization cycles. The materials used in manufacture were selected accordingly. However with every renewed preparation for use, thermal and chemical stresses will result in ageing of the products. The allowed maximum times of sterilization for motor is 250 times.</p>
Processing principles	<p>It is only possible to carry out effective sterilization after the completion of effective cleaning. Please ensure that, as part of your responsibility for the sterility of products during use, only sufficiently validated equipment and product-specific procedures are used for cleaning and sterilization, and that the validated parameters are adhered to during every cycle.</p> <p>Please also observe the applicable legal requirements in your country as well as the hygiene regulations of the hospital or clinic, especially with regard to the additional requirements for the inactivation of prions.</p>

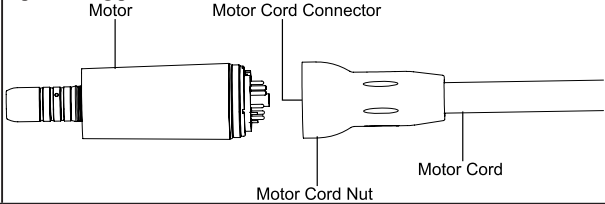
Preparation at the Point of Use	<p>Remove gross contaminants from the components with cold flow water immediately after use. And then removing the contra-angle from the motor handpiece, and then remove the motor from the Motor Cord. Store the instruments in a humid surrounding and Waiting for transfer .</p> <p> Warning: Don't use a fixating detergent or hot water (>45 °C) as this can cause the fixation of residuals which may influence the result of the reprocessing process.</p> 
Transportation	<p>Safe storage and transportation to the reprocessing area to avoid any damage and contamination to the environment.</p>
Preparation for Decontamination	<p>The products must be reprocessed in a disassembled state.</p>

Pre-clean

Tools: tray, syringe, hose, clean and dry soft cloth

① Install the bearing protection sleeve.



② Use a syringe to draw 500ml of purified water to flush the waterway and atomization airway to remove contaminants in the inner cavity.

 Do not clean the cooling air circuit, otherwise it will damage the motor.

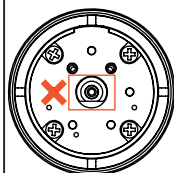

③ Wipe the water stains on the interface with clean cloth to prevent water from entering the inner cavity and damaging the bearing.

④ Install the interface protection sleeve.



⑤ Flush with running water for 2 min to remove surface contaminants. Be careful not to flush the port directly.



⑥ Flush with 500ml purified water to remove surface contaminants.



Notice:

- 1) Never reprocess this medical device in an ultrasonic device. Otherwise cause malfunction and material damage.
- 2) Do not allow any liquid enter internally into the motor either by the nose or hose connector.
- 3) Please do not use an automatic Washer-disinfector to clean the motor, otherwise the water and cleaning agents will cause damage to the motor.

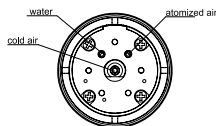

Step1: Clean the inner cavity

- ① Remove the interface protection sleeve.
- ② Use a syringe to draw 500ml of detergent to rinse the waterway and atomization airway to remove contaminants in the inner cavity.
- ③ Wipe the water stains on the interface with clean cloth to prevent water from entering the inner cavity and damaging the bearing.
- ④ Install the interface protection sleeve.



Step2: Wipe the surface

- ① Wet the clean soft cloth in the detergent and wipe the surface of the test sample thoroughly for 5 times. Change a clean soft cloth after each wipe. If there are still visible contaminants, wipe repeatedly until there are no visible contaminants.
- ② Wet the clean soft cloth in the detergent and wipe the surface of the test sample thoroughly for 5 min. If there are still visible contaminants, wipe repeatedly until there are no visible contaminants.

③ cleaning condition:

Cleaning agent:RUHOF ENDOZIMER AW PLUS WITH APA

Dilution ratio:1:270

Temperature:<60 °C

Step3: Scrub the surface

Scrub the test sample thoroughly with an instrument brush stained with detergent for 3 min.

Step4: Rinse

- ① Remove the interface protection sleeve.



- ② Use a syringe to draw 500ml of purified water to rinse the waterway and atomization airway to remove contaminants in the inner cavity.

③ Wipe the water stains on the interface with clean cloth to prevent water from entering the inner cavity and damaging the bearing.

- ④ Install the interface protection sleeve.

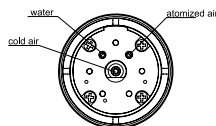

Step5: Rinse the surface

- ① Rinse the sample surface with 500ml purified water to remove the residual detergent.

Note: Do not rinse the port directly to avoid damaging the internal bearing.



Cleaning

Drying	Drying should be conducted after cleaning. Wipe off the residual water stains on the surface of the test sample with dry absorbent soft cloth.
Maintenance	<p>Visual inspection: Before packaging and auto sterilization, make sure that the motor has been maintained according to manufacturer's instruction. Visually check the integrity of the dental handpiece and the cleanliness of the device: Check the motor:</p> <ol style="list-style-type: none"> 1. If there is still visible stain on the products after cleaning, the entire cleaning process must be repeated. 2. If the appearance of the dental handpiece is obviously damaged, smashed, detached, corroded or bent, it must be scrapped and not allowed to continue to be used.
Packaging	Pack the instruments in an appropriate packaging material for sterilization. The packaging material and system refer to EN ISO11607.
Sterilization	<p>Sterilization of instruments by applying a fractionated pre-vacuum steam sterilization process (according to EN 285/EN 13060/EN ISO 17665) under consideration of the respective country requirements. Minimum requirements: 4 min at 134 °C (in EU: 5 min at 134 °C) Maximum sterilization temperature: 137 °C Put the motor in a high pressure steam sterilization bag, and seal it. And then sterilize the motor under the temperature of 134 °C (273 °F) and the pressure of 2.0 bar ~ 2.3 bar (0.20MPa~ 0.23MPa)) for not less than 4 minutes (in EU: 5 min at 134 °C) .Allow a maximum sterilization time of 20 minutes at 134°C. Drying is needed after sterilization.</p> <p> Flash sterilization is not allowed on lumen instruments!</p>
Precautions	<ol style="list-style-type: none"> 1) Only products that have been effectively cleaned or cleaned and disinfected are allowed to be sterilized; 2) Before using the sterilizer for sterilization, read the Instruction Manual provided by the equipment manufacturer and follow the instructions. 3) Do not use hot air sterilization and radiation sterilization as this may result in damage to the product; 4) Please use the recommended sterilization procedures for sterilization. It is not recommended to sterilize with other sterilization procedures such as ethylene oxide, formaldehyde and low temperature plasma sterilization. The manufacturer assumes no responsibility for the procedures that have not been recommended. If you use the sterilization procedures that have not been recommended, please adhere to related effective standards and verify the suitability and effectiveness. <p>*Fractional pre-vacuum procedure = steam sterilization with repetitive pre-vacuum. The procedure used here is to perform steam sterilization through three pre-vacuums.</p>
Storage	Storage of sterilized instruments in a dry, clean and dust free environment at modest temperatures, refer to label and instructions for use.

Reprocessing validation study information	It is the duty of the user to ensure that the reprocessing processes including resources, materials and personnel are capable to reach the required results. State of the art and often national law requiring these processes and included resources to be validated and maintained properly.
--	--

7.2 The cleaning and maintenance of main unit are as follows.

- Before each use, wipe the surface of the machine and the tail cord of the motor handpiece with a soft cloth or paper towel soaked in 75% medical alcohol. Repeat the wipe for at least 3 times.
- After each use, wipe the surface of the device and the tail cord of the motor handpiece with a soft cloth soaked in clean water (distilled or deionized water) or a clean disposable wipe. Repeat the wipe for at least 3 times.

8 Troubleshooting

Fault	Cause	Solution
Error 01	Step on the foot pedal before turning on the device, so that the voltage is too high.	Release the foot pedal and reboot.
Error 02	The input voltage is too high or too low.	Check whether the power is right.

If the problem still cannot be solved, please contact our local distributor or our company.

Note: The user must use the original accessories. Please contact our local dealer or the company for purchase. It is forbidden to use related accessories of other brands, so as to avoid damage to the electric motor or other dangers.

Warning: The equipment shall not be changed or modified without the express consent or authorization of Guilin Woodpecker Medical Instrument Co., Ltd.

9 Storage and transport

9.1 The device should be handled carefully and lightly. Be sure that it is far from the vibration, and installed or kept in a cool, dry, and ventilated place.

9.2 Do not store the machine together with articles that is poisonous, combustible, caustic, or explosive.

9.3 This machine should be stored in a room where the relative humidity is 10% ~ 93%, atmospheric pressure is 70kPa ~ 106kPa, and the temperature is - 20°C ~ +55°C.

9.4 Excessive impact and shake should be prevented during transport. Lay it carefully and lightly.

9.5 Do not put it together with dangerous goods during transport.

9.6 Avoid being exposed to sun, rain, and snow during transport.

10 After-sales service

Since the date of sales, for the device that cannot work normally for quality problem, with Warranty Card, our company is responsible for the repair. Please refer to the Warranty Card for details of warranty. The service life of the product is 5 years.

11 Environment protection

This product is a medical device and is not allowed to be arbitrarily discarded. Comply with your national regulations, guidelines and requirements for the disposal of end-of-life device.

Please remove the power cord and internal circuit board and discard them as electronic product waste according to local regulations.

Prior to disassembly and disposal the motor, motor tail and the surface of main unit must not be contaminated and must have been completely reprocessed (Cleaning/Disinfection/Sterilization) according to section 7. Then discard them as universal product waste according to local regulations.

Part	Toxic or harmful substances or elements					
	(Pb)	(Hg)	(Cd)	(Cr6+)	(PBB)	(PBDE)
Main unit	○	○	○	○	○	○
Motor handpiece	○	○	○	○	○	○
Dental contra-angle	○	○	○	○	○	○













Mechanical elements, including bolts, nuts, washers, etc.	○	○	○	○	○	○
---	---	---	---	---	---	---

○: Indicates that the content of the toxic substance in all homogeneous materials of the part is below the limit requirement stipulated in SJ/T-11363-2006 Limit Requirements for Toxic and Hazardous Substances in Electronic Information Products.

×: indicates that the content of the toxic substance in at least one of the homogeneous materials of the part exceeds the limit requirement specified in SJ/T-11363-2006.

(This product meets EU RoHS environmental protection requirements; there is currently no mature technology in the world to replace or reduce the content of lead in electronic ceramics, optical glass, steel and copper alloy.) According to the Administrative Measures on the Restriction of the Use of Hazardous Substances in Electric and Electronic Products and the Regulations on the Management of the Recycling of Waste Electric and Electronic Products and related standards, please observe the safety and precautions of the products, and after use, please recycle or dispose this product after according to the methods in local laws and regulations

12 Symbol instruction

	Type B applied part	IPX0	Ordinary equipment
	Date of manufacture		Manufacturer
	Used indoor only		Follow instructions for use
	Humidity limitation		Temperature limitation
	Can be autoclaved		CE marked product
	Appliance compliance WEEE directive		
	Atmospheric pressure for storage		
	Authorised Representative in the EUROPEAN COMMUNITY		



Protective earth(ground)

13 EMC-Declaration of conformity

The device has been tested and homologated in accordance with EN 60601-1-2 for EMC. This does not guarantee in any way that this device will not be effected by electromagnetic interference Avoid using the device in high electromagnetic environment.

Serial number	Cable name	cable length (m)	Cable type
1	Power cord (input)	1.2m	Unshielded parallel line
2	Power cord (output)	1.2m	Unshielded parallel line
3	Handle tail	1.8m	Unshielded parallel line

Technical Description Concerning Electromagnetic Emission

Table 1: Declaration - electromagnetic emissions

Guidance and manufacturer's declaration - electromagnetic emissions		
The model MT3 is intended for use in the electromagnetic environment specified below. The customer or the user of the model MT3 should assure that it is used in such an environment.		
Emissions test	Compliance	Electromagnetic environment - guidance
RF emissions CISPR 11	Group 1	The model MT3 uses RF energy only for its internal function. Therefore, its RF emissions are very low and are not likely to cause any interference in nearby electronic equipment. The model MT3 is suitable for used in all establishments, including domestic establishments and those directly connected to the public power supply network that supplies buildings used for domestic purposes.
RF emissions CISPR11	Class B	
Harmonic emissions IEC 61000-3-2	Class A	
Voltage fluctuations / flicker emissions IEC 61000-3-3	Complies	

Technical Description Concerning Electromagnetic Immunity

Table 2: Guidance & Declaration - electromagnetic immunity

Guidance & Declaration — electromagnetic immunity			
The model MT3 is intended for use in the electromagnetic environment specified below. The customer or the user of the model MT3 should assure that It is used in such an environment.			
Immunity test	IEC 60601 test level	Compliance level	Electromagnetic environment - guidance
Electrostatic discharge (ESD) IEC 61000-4-2	±8kV contact ±2, ±4, ±8, ±15kV air	±8kV contact ±2, ±4, ±8, ±15kV air	Floors should be wood, concrete or ceramic tile. If floors are covered with synthetic material, the relative humidity should be at least 30 %.
Electric fast transient/burst IEC 61000-4-4	±2kV for power supply lines ±1kV for Input/output lines	±2kV for power supply lines	Mains power quality should be that of a typical commercial or hospital environment.
Surge IEC 61000-4-5	±0.5, ±1kV line to line ±0.5, ±1, ±2kV line to earth	±0.5, ±1kV line to line ±0.5, ±1, ±2kV line to earth	Mains power quality should be that of a typical commercial or hospital environment.
Voltage dips, short interruptions and voltage variations on power supply input lines IEC 61000-4-11	<5 % U_T (>95% dip in U_T) for 0.5 cycle <5 % U_T (>95% dip in U_T) for 1 cycle 70% U_T (30% dip in U_T) for 25 cycles <5% U_T (>95 % dip in U_T) for 250 cycles	<5 % U_T (>95% dip in U_T) for 0.5 cycle <5 % U_T (>95% dip in U_T) for 1 cycle 70% U_T (30% dip in U_T) for 25 cycles <5% U_T (>95 % dip in U_T) for 250 cycles	Mains power quality should be that of a typical commercial or hospital environment. If the user of the models MT3 requires continued operation during power mains interruptions, it is recommended that the models MT3 be powered from an uninterruptible power supply or a battery.

Power frequency (50/60 Hz) magnetic field IEC 61000-4-8	30A/m	30A/m	Power frequency magnetic fields should be at levels characteristic of a typical location in a typical commercial or hospital environment.
NOTE U_T is the a.c. mains voltage prior to application of the test level.			

Table 3: Guidance & Declaration - electromagnetic immunity concerning Conducted RF & Radiated RF

Guidance & Declaration - Electromagnetic immunity			
The model MT3 is intended for use in the electromagnetic environment specified below. The customer or the user of the models MT3 should assure that it is used in such an environment.			
Immunity test	IEC 60601 test level	Compliance level	Electromagnetic environment - guidance

<p>Conducted RF IEC 61000-4-6 Conducted RF IEC 61000-4-6 Radiated RF IEC 61000-4-3</p>	<p>3 Vrms 150 kHz to 80 MHz 6 Vrms ISM frequency band 3 V/m 80 MHz to 2.7 GHz</p>	<p>3V 6V 3V/m</p>	<p>Portable and mobile RF communications equipment should be used no closer to any part of the models MT2, including cables, than the recommended separation distance calculated from the equation applicable to the frequency of the transmitter. Recommended separation distance $d=1.2 \times P^{1/2}$ $d=2 \times P^{1/2}$ $d=1.2 \times P^{1/2}$ 80 MHz to 800 MHz $d=2.3 \times P^{1/2}$ 800 MHz to 2.7 GHz where P is the maximum output power rating of the transmitter In watts (W) according to the transmitter manufacturer and d Is the recommended separation distance in meters (m). Field strengths from fixed RF transmitters, as determined by an electromagnetic site survey,a should be less than the compliance level in each frequency range.b Interference may occur In the vicinity of equipment marked with the following symbol: </p>
<p>NOTE 1 At 80 MHz end 800 MHz. the higher frequency range applies. NOTE 2 These guidelines may not apply in all situations. Electromagnetic propagation is affected by absorption and reflection from structures, objects and people.</p>			

a Field strengths from fixed transmitters, such as base stations for radio (cellular/cordless) telephones and land mobile radios, amateur radio, AM and FM radio broadcast and TV broadcast cannot be predicted theoretically with accuracy. To assess the electromagnetic environment due to fixed RF transmitters, an electromagnetic site survey should be considered. If the measured field strength in the location in which the model MT3 is used exceeds the applicable RF compliance level above, the model MT3 should be observed to verify normal operation. If abnormal performance is observed, additional measures may be necessary, such as reorienting or relocating the model MT3.

b Over the frequency range 150 kHz to 80 MHz, field strengths should be less than 3V/m.

Table 4: Recommended separation distances between portable and mobile RF communications equipment and the model MT3

Recommended separation distances between portable and mobile RF communications equipment and the model MT3			
The model MT3 is intended for use in electromagnetic environment in which radiated RF disturbances is controlled. The customer or the user of the model MT3 can help prevent electromagnetic interference by maintaining a minimum distance between portable and mobile RF communications equipment (transmitters) and the model MT3 as recommended below, according to the maximum output power of the communications equipment.			
Rated maximum output power of transmitter W	Separation distance according to frequency of transmitter m		
	150kHz to 80MHz $d=1.2 \times P^{1/2}$	80MHz to 800MHz $d=1.2 \times P^{1/2}$	800MHz to 2,7GHz $d=2.3 \times P^{1/2}$
0,01	0.12	0.12	0.23
0,1	0.38	0.38	0.73
1	1.2	1.2	2.3
10	3.8	3.8	7.3
100	12	12	23

For transmitters rated at a maximum output power not listed above, the recommended separation distance d in meters (m) can be estimated using the equation applicable to the frequency of the transmitter, where P is the maximum output power rating of the transmitter in watts (W) accordable to the transmitter manufacturer.

NOTE 1 At 80 MHz and 800 MHz, the separation distance for the higher frequency range applies.

NOTE 2 These guidelines may not apply in all situations. Electromagnetic propagation is affected by absorption and reflection from structures, objects and people.

Scan and Login website
for more information



Guilin Woodpecker Medical Instrument Co., Ltd.
Information Industrial Park, Guilin National High-Tech
Zone, Guilin, Guangxi, 541004 P. R. China

Tel:

Europe Sales Dept.: +86-773-5873196

North/South America & Oceania Sales Dep.:+86-773-5873198

Asia & Africa Sales Dep.:+86-773-5855350 Fax: +86-773-5822450

E-mail: woodpecker@glwoodpecker.com, sales@glwoodpecker.com

Website: <http://www.glwoodpecker.com>



MedNet EC-Rep GmbH
Borkstrasse 10 · 48163 Muenster · Germany

ZMN-SM-141 V1.2- 20220519